

Cruzin Cooler.com

- PARTS
- SALES
- SERVICE

To order parts, accessories or for more information about new Cruzin Cooler products go online to:

www.cruzincooler.com

Cruzin Cooler, LLC is the exclusive global importers of Cruzin Coolers and has licensed patents or patents pending on the concepts and designs surrounding our motorized ice chests.

Copyrights, trademarks, patents and designs are the sole and exclusive property of Cruzin Cooler, LLC. Federal Law strictly prohibits the unauthorized reproduction, copying or use of any mark, design or copyrighted material. All rights reserved.

Authorized service is only available from
Cruzin Cooler, LLC.

MADE IN CHINA

Specifications may change without notice.

Cruzin Cooler, LLC Austin, TX

Revision 3/03/05a. ©Copyright 2005 Cruzin Cooler, LLC.

Patents Pending-All rights reserved.

Cruzin Cooler®

PATENTS PENDING

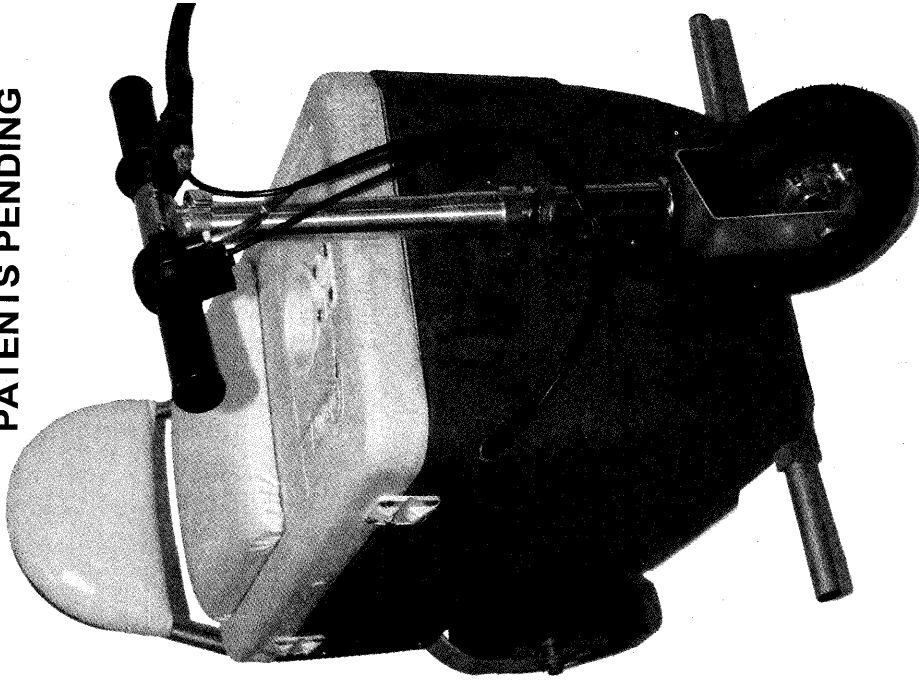

Owner's Manual

50 SERIES CRUZIN COOLERS

Rev 1.10

STEP 3:

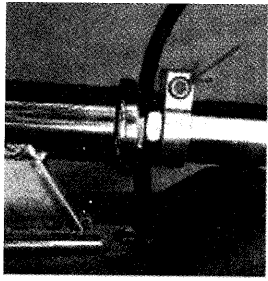

Figure "C"

Slide upper "T" bar onto lower fork assembly. Be sure retainer clamp is around upper "T" bar. Face "T" bar so that push pin holes for handles are facing outward. Front facing

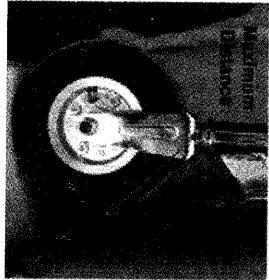
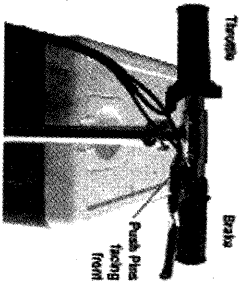

Figure "D"

fork is offset for tire stability so the tire is slightly forward. Be sure that front tire is in position so that it is **farthest from cooler body**, see Fig. D. Tighten clamp to secure upper "T" bar. Tighten clamp with enclosed allen wrench, so that upper "T" bar is secure and unable to be turned separately from lower fork, Fig. C.

STEP 4:



Insert throttle and brake handle into the ends of the "T" handle with the throttle on the right side, when you are sitting on the cooler. The handlebars must be inserted completely into the "T" bar so that the brass push pins are clearly visible through the "T" bar lock holes. Failure to fully engage the handles into the "T" bar may cause serious injury.

Must see brass push pins in holes!

STEP 5:

You can adjust the handlebars to the desired height by loosening the clamp and tightening where desired.

3. IMPORTANT FINAL ASSEMBLY CHECK POINTS

Always check your cooler prior to operating for loose parts, worn tires or unsafe items. Repair or replace any worn or damaged items prior to operation.

If you are purchasing a gasoline unit be sure that you mix the gasoline and oil in a ratio of:

25:1

This is twenty-five parts of gasoline to one part of oil. This is approximately 1/2 cup of oil, or 4 oz. Per gallon of gas.

GENERAL & GAS PARTS

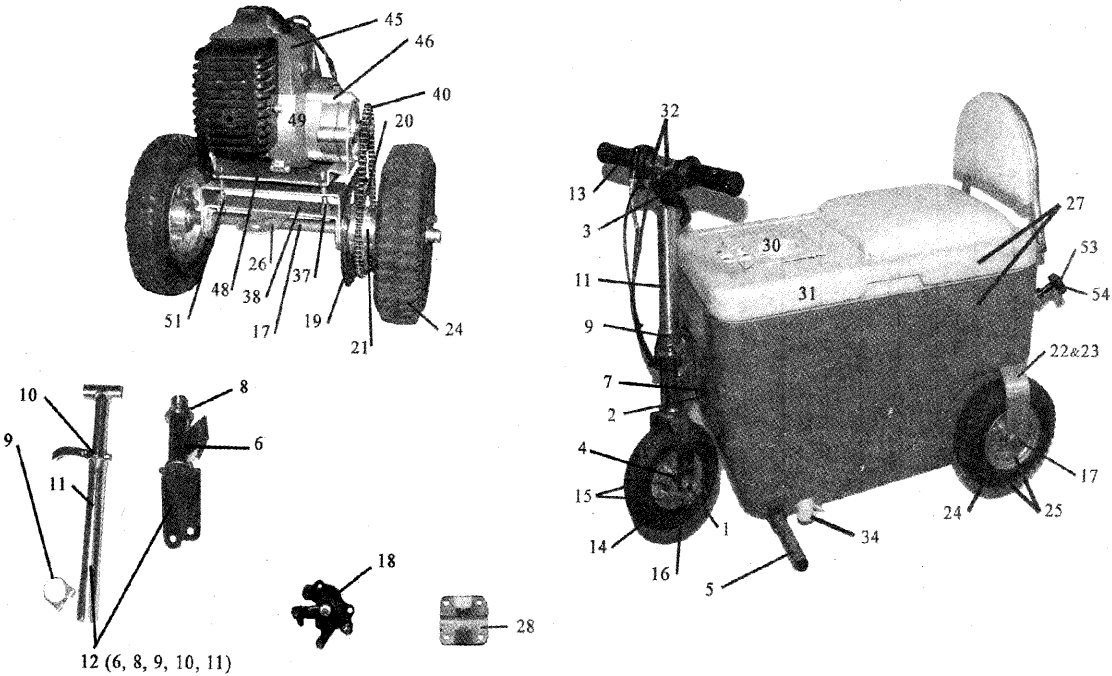

REPLACEMENT PARTS, continued

39	50-0154	Carburetor
40	50-0155	Chain
41	50-0156	Clutch, inner w/nut
42	50-0157	Clutch, outer ring, w/nut
43	50-0158	Fuel hose set
44	50-0159	Fuel tank
45	50-0160	Motor housing cover
46	50-0161	Gear/clutch housing w/bolts
47	50-0162	Motor mount bolts
48	50-0163	Motor mount plate
49	50-0164	Motor, complete 33cc
50	50-0165	Muffler w/bolts
51	50-0166	Nuts, adjustment (2)
52	50-0167	Plate, inner chassis main
53	50-0168	Pull cord assembly, rope handle
54	50-0169	Pull cord handle
55	50-0170	Plate, outer axle support
ELECTRIC PARTS		
56	50-0200	250 Watt motor
57	50-0201	500 Watt motor
58	50-0202	Battery, 250 watt 12 oz
59	50-0203	On/off switch
60	50-0204	Battery Charger 110V, 250 watt
61	50-0205	Circuit breaker
62	50-0206	Charger port
63	50-0207	Throttle assembly handle bar with cable
64	50-0208	Speed controller 250 watt
65	50-0209	Cover, control mount plate
66	50-0210	Plate, motor mount plate
67	50-0211	Battery for 500 watt (3) required
68	50-0212	Battery Charger 500 watt 36V
69	50-0213	Speed controller:500 watt 36V
70	50-0214	Fuses kit 250 Watt
71	50-0215	Fuse kit 500 Watt
72	50-0167	Plate, inner chassis main
73	50-0170	Plate, outer axle support

4. HOW TO OPERATE

Before you start riding your cooler check the brakes for proper operation. The brakes should be tight enough to stop the cooler, but not too tight as to keep the vehicle from moving freely while the brakes are released. If they are too loose you can tighten the adjustable nut on the brake lever. If the brakes will not tighten enough or are too tight you can adjust the cable at the caliper in the rear of the cooler.

GASOLINE:

1. You must first add the gasoline/oil mixture to the fuel tank.
2. Reach into the cooler and pump the primer bulb on the bottom of the carburetor.
3. Lift the choke lever to the upper position.
4. Pull the handle until the unit starts. You may need to turn the throttle to the full open position to get the unit started. We recommend that you keep a can of starting ether handy in cases where you are having trouble starting the cooler. A small spray towards the carburetor will usually get the unit started easily.
5. Move the choke lever down, shut the lid and you are ready to go.
6. Twist the right throttle lever for power, release to decrease power.
7. Start off slow to get use to the driving characteristics of your new cooler. Check your brakes for proper operation.

ELECTRIC:

1. Make sure that batteries are charged on your new cooler.
2. Turn on the on/off switch located on the handlebar or in rear plate.
3. Twist the right throttle lever for power, release to decrease power.
4. Start off slow to get use to the driving characteristics of your new cooler. Check your brakes for proper operation.

In the event of brake failure you can always stop you cooler by placing your feet (with rubber soled shoes) down and is considered secondary or backup braking.

5. OPERATIONAL LEGAL ISSUES

Operation on public property (roads and highways) is governed by Federal, State and Local laws. This cooler might or might not be legal in some cities or counties around the US; therefore it is up to the operator to check on the legality of the operation of these coolers on public property. It is possible that they may be legal in one city and against the law in another.

The electric coolers are more likely to be legal than the gas units. This is because of the legality of disabled electric vehicles in many cities. It is solely the responsibility of the operator to find out if it is legal to operate the cooler at any particular location.

REPLACEMENT PARTS

GENERAL PARTS	
1	50-0001 Axle bolt, front w/nuts, spacers
2	50-0002 Bracket, front mount body
3	50-0003 Brake Cable w/handle
4	50-0004 Bearing, front wheel
5	50-0005 Foot Pegs (2)
6	50-0006 Fork, with mount collar & plate
7	50-0007 Steering assembly retainer clip
8	50-0008 Steering collar bearing set w/nuts
9	50-0009 Steering T bar lock ring
10	50-0010 Steering T bar slide lock cam
11	50-0011 Steering T bar, front
12	50-0012 Steering, fork assembly complete
13	50-0013 Throttle handle with cable
14	50-0014 Front tire and tube
15	50-0015 Tire front, tube, rim, bearings
16	50-0016 Front Rim, 2 piece
17	50-0050 Axle, rear
18	50-0051 Brake caliper
19	50-0052 Brake disk rotor
20	50-0053 Gear, drive
21	50-0054 Rim, rear right with drive hub
22	50-0055 Stabilizer bracket, left
23	50-0056 Stabilizer bracket, right
24	50-0057 Tire, tube, rear
25	50-0058 Tire, tube, rim left rear
26	50-0059 Trailer Hitch
BODY PARTS	
27	50-0100 Body with lid
28	50-0102 Hinge (2)
29	50-0103 Latch
30	50-0104 Lid, drink
31	50-0105 Lid, main
32	50-0106 Retainer push bottom clips (2)
33	50-0107 Air intake scoops
34	50-0108 Drain Plug
MOTOR PARTS	
35	50-0150 Air filter
36	50-0151 Air filter cover with nut
37	50-0152 Bolt, L adjustment bolts (2)
38	50-0153 Bracket, outer axle

4. NORMAL MAINTENANCE

Be sure to see if your chain needs tightening. It must not be too tight or too loose. If the chain is too tight it will keep the cooler from operating at full speed and will use more power. If the chain is too loose it will come off or start slipping. This will prematurely wear the sprocket teeth down.

Check the tires for wear and proper inflation. If the tire pressure is too low it could cause the cooler to slow and might drag over small obstacles. If the tires are inflated to high they may hit the support brackets or explode.

Check the air filter every month for any accumulated dirt, especially if driving the unit in a dusty or dirty area.

Check wheel bearings and front end bearings for wear and tear. It is possible for these to eventually wear out and become dangerous. For chain adjustment information see 14.F

Recommended Maintenance Schedule

	100 miles	200 miles	400 miles	600 miles
Brakes	A	A	R	A
Tires	I	I	I	R
Cables	A	A	A	A
Spark Plug	I	R	I	R
Chain	L, A	L, A	L, A	L, A
Air filter	C	C	C	R
C-Clean	R-Replace	I-Inspect	A-Adjust	L-Lubricate

5. CLEANING

You can clean the cooler with soap and water or even a powered bleach product for the food and beverage area. Do not get water into the motor area. This could cause failure of electrical components. You can wipe down your motor and motor area with normal motor cleaning products. DO NOT use alcohol, solvents, alcohol-based products, or ammonia based products. These products may melt or discolor plastics and decals.

6. WARRANTY

Manufacturer warranties products to be free of manufacturing defects for a period of 120 days from the date of original purchase. This warranty does not cover wear and tear, tires, tubes, brakes or cables, overloading.

16. TECHNICAL SPECIFICATIONS

The following technical specifications is the best data available at the time of printing. Some specifications may be different than what is shown in the table below.

Specification	English	Metric
Maximum Speed	12 mph	19.3 kph
Distance per charge	Maximum of 8 hours	Maximum of 8 hours
Distance per tank	n/a	n/a
Weight Capacity	250 lbs. with cargo	113.4 kg. with cargo
Climbing capacity	Up to 10% depending on load	Up to 10% depending on load
Size	Width	17.32 inches
	Height	18.11 inches
	Length	27.56 inches
Net weight	Gas	38 lbs
	Electric	53 lbs--75 lbs
Tire Pressure	30 psi	2.05 kg/cm
Motor Ratings	Gas approx. 1.5 hp	Gas approx 1.5 hp
Electric power rating	250-500 watt	250-500 watt
	24V-250 watt	24V-250 watt
Voltage rating	36V-500 watt	36V-500 watt

ELECTRICAL PARTS

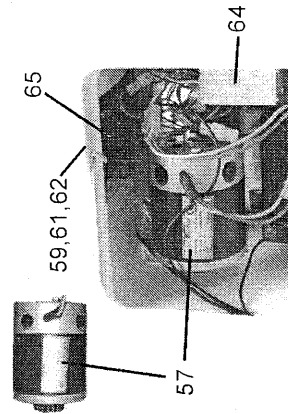

Electrical Parts

physical damages or failure from misuse. This limited warranty is issued to the original purchaser only. If there is a defect in workmanship or materials during the warranty period, we will repair, replace or refund the product, at our option. This warranty is voided if the product is used in a manner other than for what it was designed for, modified in any way, overloaded, leased or rented, used for racing or for off road purposes, unreasonably used, improperly assembled, or damaged by accident, negligence, or misuse. The manufacturer is not liable for incidental or consequential damages or losses due directly or indirectly from the use of this product. THIS LIMITED WARRANTY EXCLUDES shipping costs, compensation for inconvenience or loss of use, any consequential or incidental damages. RETURNS must be authorized by Cruzin Cooler, must be within the warranty period and must be returned to our facilities for repair, replacement or refund.

4. DISCLAIMER

Purchaser/user/assigns shall indemnify, protect, defend and hold harmless Cruzin Cooler, LLC its partners, officers, employees and agents, from and against any and all claims, costs, liabilities, losses, damages, injuries, judgments and expenses (collectively, the "Claims" including, without limitation, attorney's fees, court costs, including those incurred at the trial and appellate levels and in any bankruptcy, reorganization, insolvency or other similar proceedings, and other legal expenses, arising out of or resulting from: (i) accidents, injuries or death from Cruzin Cooler products; (ii) any misrepresentation, breach of warranty or negligence of Cruzin Cooler, it's directors, officers, managers, employees or agents, and (iii) incidental or consequential damages or losses due to directly or indirectly from the use of this product. I have read the Safety Warnings, Warranty and Disclaimer and understand and agree to these terms, as a condition of operation of any Cruzin Cooler product.

5. SERVICE

The most current service information can be obtained online at the Cruzin Cooler's web site at www.cruzincooler.com. At the time of printing all factory service will be performed at our service facilities in Houston, TX. We always recommend that the owner keep the original box in the event that the cooler needs to be sent in for service.

6. ACCESSORIES

You can order any accessory we offer online at www.cruzincooler.com. You can also purchase most accessories from any retailer where you purchased the original unit from.

12. REGISTRATION

There are two ways to register: you can either register your cooler by email to register@cruzincooler.com, or by mailing the registration form to the address on the enclosed card.

13. PARTS

Any part you could ever need is available online at www.cruzincooler.com. We stock over 10,000 parts for your cooler everyday. Parts are quick and easy to order and recommend that all parts be ordered over the Internet, to be sure that you can verify the parts you are ordering, to prevent possible mistakes.

14. TROUBLESHOOTING

A. I have trouble starting the gas unit, What do I do?

- Keep a small can of starting ether handy to make cold starting easier. Almost all 2-cycle motors may take a few pulls to get going.
- To start your cooler use the following procedure:
- Pump the primer bulb under the carburetor.
 - Move the choke lever up to choke the carburetor.
 - Turn the throttle all the way to maximum and pull start cord.
 - If it does not start after a few pulls you can spray a little ether close to the air cleaner. Remember ether is a dangerous flammable gas, which could ignite and cause a fire!
 - Check to see that the carburetor bolts are tight and that the air cleaner is clean.
 - Check the spark plug. Since this is a two-cycle motor the plug can sometimes foul or become so contaminated that it is difficult to start the cooler.

B. The electric unit will not start, what should I do?

There are two fuses in these units. One in the exterior charge plate area (this may be changed to a circuit breaker) and one in the electronic controller inside the cooler where all of the wires converge. Check these first. If they are good check your battery connections. If the connections are good you will need to get a voltmeter to check your power at the motor and at the batteries. Ohm out the motor. If it is good your problem lies in the throttle or the controller.

C. My unit is under warranty and it won't start, what should I do?

Follow the steps above first. If you still have problems you can ship it to our Service Center. Also try service@cruzincooler.com.

D. What do I do if I need parts?

This is one of our biggest target areas for complete customer satisfaction. One of the biggest complaints from other people who

buy scooters from overseas is lack of parts and service, therefore we will stock everything you could ever need for your cooler, all the time.

E. What do I do if I wrecked my cooler and it needs service?

If you damage your cooler beyond normal repair you can ship it to our service center. We will call or email you a quote to repair or replace your cooler. service@cruzincooler.com.

F. The chain is loose, slipping or comes off frequently?

- Loose chain - Loosen the two lock nuts at the bottom rear of the cooler. Adjust the two larger nuts equally until the proper tension is achieved. Retighten the two lock nuts.
 - Slipping - Loosen the two lock nuts at the bottom rear of the cooler. Adjust the two larger nuts equally until the proper tension is achieved. Retighten the two lock nuts.
 - Comes off - The chain may be out of alignment due to excessive lateral stress. Check to see if the motor sprocket and lower drive sprocket are aligned correctly. If not you may need to loosen the two set screws on the gear/disc spacer and realign gears by rotating gear/disc assembly on threaded hub to correct alignment and retighten the two set screws to correct the alignment problem.
- G. The cooler sputters and stops and will not restart. What do I do?
- The motor may be getting too hot. Try pumping the primer bulb and see if you are getting lots of air in the lines by looking through the clear return line. If there are a lot of bubbles you may be over exerting the cooler. Let the unit cool and try to lower the load or stress on the unit. Too heavy a load, too hot an operating environment or going up and down hills can all contribute to overheating.

15. ELECTRICAL CHARGING INSTRUCTIONS

Charge when low or every 90 days to keep batteries fresh.

- Turn off power switch
- Plug charger into Cooler first and then into wall outlet. The red light will come on if the batteries need charging. If the red light does not come on and you know that the unit needs charging you may have a service problem. Some units do not have lights.
- Charger will need 6-8 hours of charging to reach the full battery capacity.
- Unplug charger from unit and place rubber socket protector back over charging port.

The battery in your unit is a sealed lead-acid battery. If you notice a leak or crack in the battery dispose of it immediately, according to local disposal of hazardous waste laws.